

PEDESTRIAN ALUMINIUM ALLOY RAILINGS - TYPE B

JOB No: 0414-NYI-0196 ID :

DELIVERY DATE _____

Morning Afternoon
 Before After Time: _____

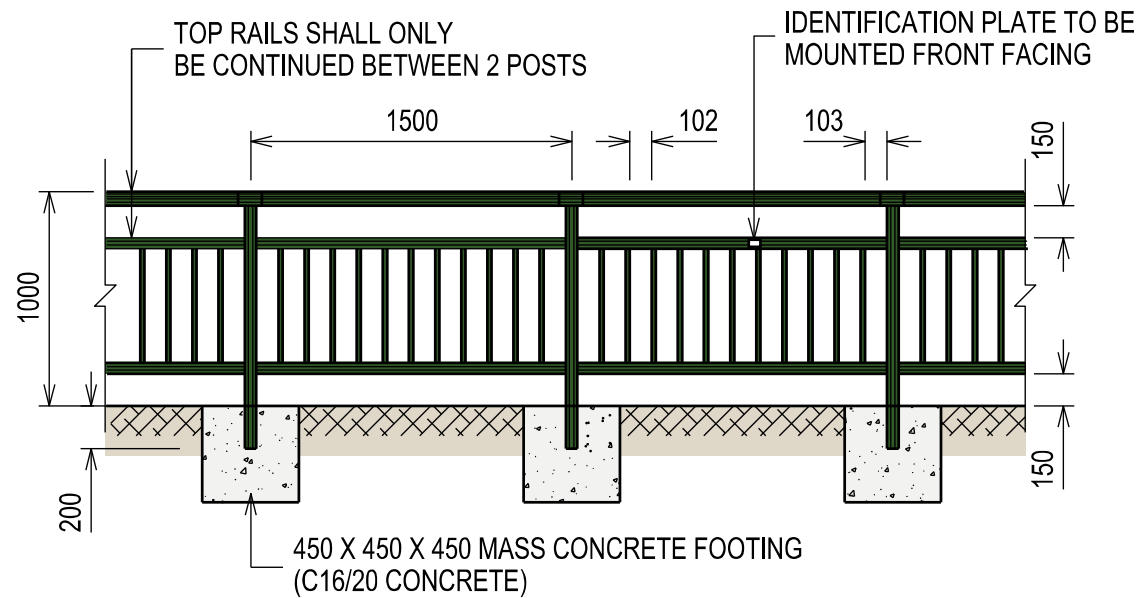

TYPE B ALUMINIUM ALLOY RAILINGS

SCALE 1:50

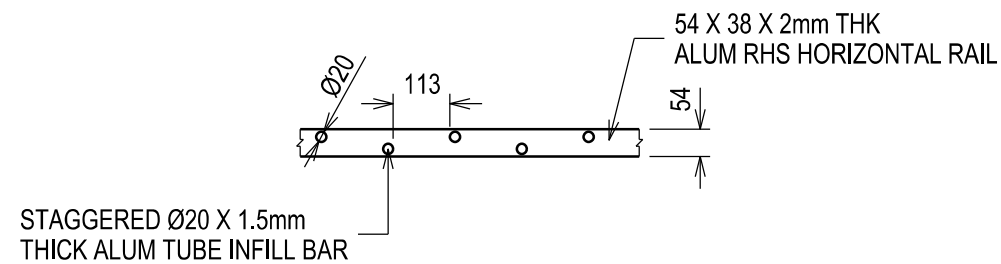

PART PLAN OF INFILL BAR ARRANGEMENT (TYPE F)

SCALE 1:20

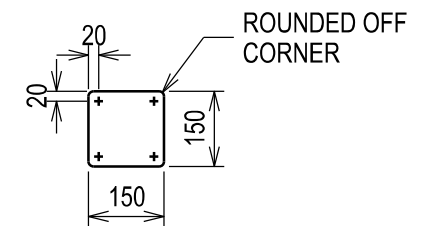

DETAIL OF BASE PLATE

SCALE 1:20

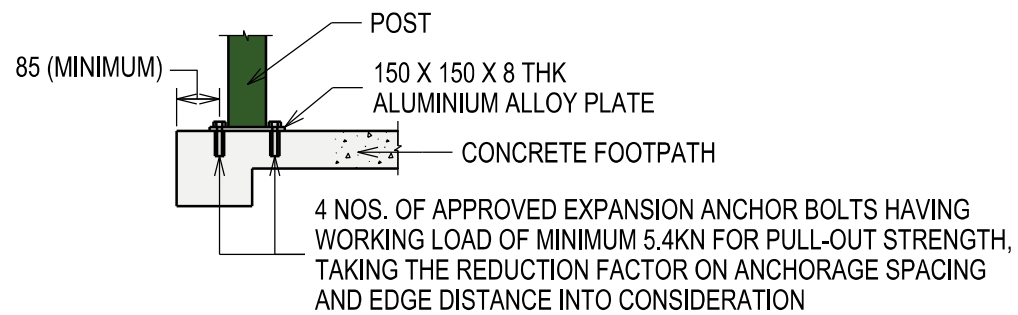

ANCHORAGE DETAIL OF POST TO FOOTPATH

SCALE 1:20

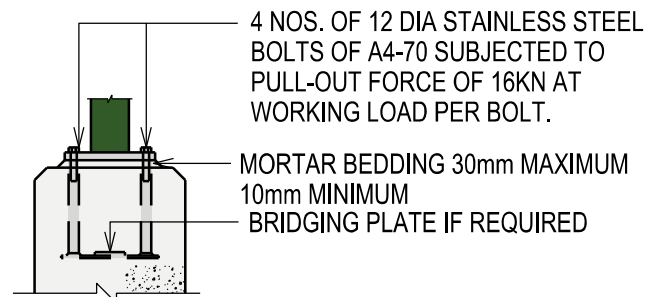

TYPICAL DETAIL OF RAILING FIXING TO CONCRETE STRUCTURE BY CAST-IN CRADLES

Note : Cast-in cradles may be used as an alternative when the embedded depth is not available

SCALE 1:20

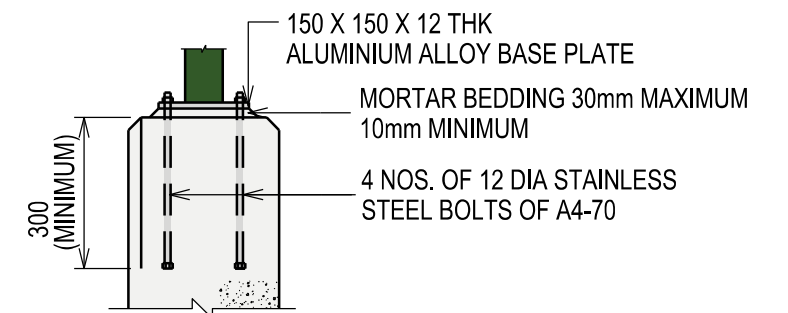

TYPICAL DETAIL OF RAILING FIXING TO CONCRETE STRUCTURE BY INDIVIDUAL ANCHORAGE FIXINGS

SCALE 1:20